



# Manufactured Home Update

Oregon Department of Consumer & Business Services ■ Building Codes Division

Spring 2003

## HUD committee meets, considers proposals

Oregon BCD team develops consumer-assistance plan for U.S.

By Larry Iverson

The national HUD Consensus Committee, chaired by Dana Roberts, has been holding conferences around the country to develop proposals for changes to HUD standards and regulations.

The Consensus Committee allows input from industry and homeowners to help guide the regulatory organization.

The committee will make recommendations for updating and revising construction standards and HUD program regulations to the HUD secretary, who is required to act on the committee recommendations within specified time frames and processes.

Subcommittees for construction standards and enforcement and regulations will propose changes.

The Construction Standards Subcommittee considered about 150 reference updates to the federal standard.

The Enforcement and Regulations Subcommittee will put forth two proposals: one calling for national consumer-assistance process and a regulation dealing with landowners. The proposed landowner regulation would prevent state and local jurisdictions from allowing landowners to impose covenants, conditions, and restrictions that would prohibit manufactured housing if the jurisdictions allow other forms of single-family residential construction on that land.

The consumer-assistance proposal, developed by Oregon industry and committee representatives, would provide a national process for dealing with consumer complaints. For the first time, HUD regulations would recognize that parties other than the manufacturer may cause problems with the home prior to homeowner occupancy. ■

## Inside

Job well done deserves recognition .....	2
Training Update .....	2
Crawlspace openings: "I can't get in!" .....	3
Preliminary compliance reports.....	3
Close-up plastic is always important .....	4
Return insignia, labels on damaged homes .....	4
Correct fireplace chimney installation.....	5
Vinyl skirting, close-up trim .....	5
Quizzin' Corner.....	6
New alternate-construction requirements .....	7
Meet Ann McGovern .....	7
Good installations recognized .....	8

## Take care with grading, draining when preparing lots for new homes

By Dwight West

Building Codes Division has been getting more consumer-complaints cases that are a direct result of the grading and drainage of newly set manufactured homes. When contractors are preparing the site for a new- or secondary-set manufactured home, there are some considerations:

The site grading and drainage must provide run-off from the manufactured dwelling and lots and stands need to have adequate drainage and proper grading that diverts surface water away from manufactured dwellings.

See Grading, Page 4

# Job well done deserves recognition

By Albert Endres

Field inspectors see all kinds of work and hear many stories while doing inspections. Too often, the work we see and the stories we hear are not representative of good practices.

Sometimes, though, we see work that makes an exemplary impression. During a recent crawling inspection under a home, someone observed an excellent example of workmanship. Take a look at the accompanying picture, which proves the installer in this case took pride in his work and was devoted to doing a good job.

This example was a simple application of code but it was the best example of doing a job right that I can recall. Installer MDI 459, Gerald Breuer, placed the installation tag on the home.

Anyone who wants to know how to insulate a pressure line and shut-off valve should study this picture.



This picture shows a pressure-line and shut-off-valve insulation done exceptionally well. Other installers can learn from this example.

## Training Update

### BCD continues to hold no-cost monthly educational seminars

By Albert Endres

The Manufactured Home Section of BCD continues to provide monthly training to industry, inspectors, and staff.

The training sessions focus on manufactured home issues, but some training crosses over to other disciplines. Trainers are usually staff members, but, occasionally, outside experts are brought in. We have had classes on gas piping construction, mold issues, and meter-base installation.

Upcoming classes will cover asphalt roofing installation, GFCI operation, floor construction, electrical testing in the field, moisture-meter operation, alternate-construction homes, and welding inspection.

Classes are held on the next to last Friday of each month at BCD's main office, 1535 Edgewater St. NW in Salem. Anyone who is interested is welcome to attend. Please call Albert Endres, (503) 378-5975, for exact dates and topics. ■

### Ground-fault circuit-interrupter class set for May 30

By Albert Endres

On Friday, May 30, you have the opportunity to attend and participate in BCD's monthly educational seminar on the basics of ground-fault circuit-interrupters.

Your input, questions, and assistance are always welcome. Perhaps you will learn something — or perhaps you can help us learn by participating in the class.

We will have a PowerPoint presentation as well as a practical demonstration. The class is scheduled for 8 a.m., Conference Room C, at the Salem office, 1535 Edgewater Street NW, Salem. Call Albert Endres, (503) 378-5975, if you have any questions.

Thanks to Redman/Champion Homes and Skyline Corporation for providing some of the GFCIs. ■

# Crawlspace openings: “I can’t get in!”

---

By Tom Nicolai

Most consumer-assistance inspections require crawling under homes. But we find openings obstructed by electrical, gas, or plumbing lines or blocking. Sometimes homeowners use the access area to store their belongings.

Consider the consequences if it became imperative to get under the home and unsuitable access made it extremely difficult — or impossible — to get in.

Section 3-10.2 of the Oregon Manufactured Dwelling and Park Specialty Code deals with under-floor access in manufactured homes. The code is intended to ensure easy access for maintenance, inspection, and repair.

Usually, access is through the skirting or at ground-level in pit-set homes. Both must meet these criteria:

A clear opening of 18 inches by 24 inches must be maintained. There must be at least 30 inches directly in front of and behind each access door panel. The skirting access must not be obstructed by pier supports; structural members; plumbing, electrical, gas, or mechanical equipment; or by any other material or method. There must be no more than four devices to open or remove the access door or panel and the devices must not require special tools or more than five pounds of force to open.



This crawlspace access is blocked by plumbing lines and boxes. Such blocks are a no-no; almost all home inspections require a tour of the crawlspace. In your installations, make sure there is clear access to the crawlspace.

When planning the installation of the skirting, make a mental note or have a drawing the area of least — or no — obstruction and put the access there. If an inspector should find the access blocked, the access will need to be moved. This could lead to a lot of unnecessary work and expense. ■

# Attend to preliminary compliance reports

---

By Albert Endres

A preliminary compliance report is a formal report used to provide information about possible violations of Oregon’s building laws or rules and occupational licensing laws. It is generally filled out by an inspector to report an individual or business whom the inspector feels has violated one of the laws or rules. Individuals may also turn in a report if they have specific knowledge of a violation. Once a report is submitted, our Regulatory Services Section begins an investigation to determine the validity of the report and to begin creating the basis for civil action.

If you are the subject of the report and get a notice from Regulatory Services, you are advised to comply with their requests for information and do what is necessary to minimize any consequences that may result from the allegations.

If you are the initiator of the report, we ask that the information be as accurate as possible, with all sec-

tions of the form completed the best of your knowledge. If you need assistance filling out the form, please contact Roseanne Nelson, (503) 378-5324. If you are an inspector, we also ask that you make every effort to provide the proper code, rule, or statute reference that was violated. This aids investigators in their responsibilities. It is important to remember that the investigators are experts in their field but not code experts in each discipline in which there may be a violation.

The report is available on line at our Web site, [www.oregonbcd.org/compliance.html](http://www.oregonbcd.org/compliance.html) or you can call Roseanne and she will fax or mail you one.

The Building Codes Division can take action with violations of Oregon Statute, Administrative Rule, or Specialty Code, but cannot take action concerning violation of municipal ordinances not related to state-wide regulations. ■

# Close-up plastic is always important in Oregon

---

By Tom Nicolai

Although winter is winding down, Oregon rainstorms can swoop down on us at any time — and they're hard on manufactured homes left exposed to the weather during extended stays on holding lots. That's why the close-up plastic installation on homes is so important. Follow-through is needed to ensure that close-up plastic remains secure after a home leaves the plant.

Problems also occur when homes used as display models on dealer lots are sold, torn down, and closed up for shipping. It's very important that when a home is resealed with plastic for any reason that the plastic is installed properly to prevent weather damage.

Improperly installed or damaged plastic allow wind and water to damage homes. Rain can ruin floor decking,

insulation, joists, and walls. Moisture can encourage mold and mildew growth in floors and walls and make new homes look and smell like extremely old homes.

Imagine how customers feel when their brand new home is ruined before it is even set up. Think of the expense to return this home to its original state — not to mention legal costs should homeowners decide to sue.

Manufacturers, dealers, and transportation companies need to take every possible step to ensure the homes are protected en route. If water damage is discovered on a lot, dealers and installers should be notified so they can take the necessary steps to correct problems before installation is completed. ■

# Return insignia, labels on damaged homes

---

By Albert Endres

Occasionally a manufactured home is damaged to the extent that it appears to be unrepairable. If a building department is involved and has determined that a home is not repairable, the insignia of compliance or HUD label must be removed and returned to Building Codes Division.

If you are sending us an insignia, it is important that you attempt to include the name of the manufacturer and serial or VIN number of the home.

At BCD, we record this information in a database so that we can track the home to ensure that it is indeed scrapped and not resold.

There have been a few instances recently in which we inspected homes to replace HUD labels or Oregon Insignias and found that the homes had undergone some type of damage, and attempts to reclaim them had been made.

In some cases, we are able to reconstruct the events and approve the home; in others, it was not possible.

The reference for removal and return of insignia is in the Manufactured Dwelling and Park Specialty Code, Section 1-9.4 and 1-9.6. If you have questions about this process, call Albert Endres, (503) 378-5975. ■

---

## Grading

Make sure that the top of any foundation wall, perimeter retaining wall, or basement wall extends a minimum of 12 inches above the elevation of the street or driveway adjacent to the manufactured dwelling. Lots need to have drainage sufficient to prevent standing water, excessive soil saturation, or erosion. The ground around the perimeter of the manufactured

home needs to have a minimum fall of three inches in five feet; any sidewalks, patio slabs, or driveways adjacent to the manufactured home stand or foundation shall have a minimum slope of a quarter inch per foot.

If you have questions regarding grading or drainage, call Dwight West, (503) 378-2670. ■

**Visit the BCD Web site: [www.oregonbcd.org](http://www.oregonbcd.org)**

It's the quickest and easiest way to get previous issues of this newsletter and other BCD publications.

## An illustration of the “10-foot rule”

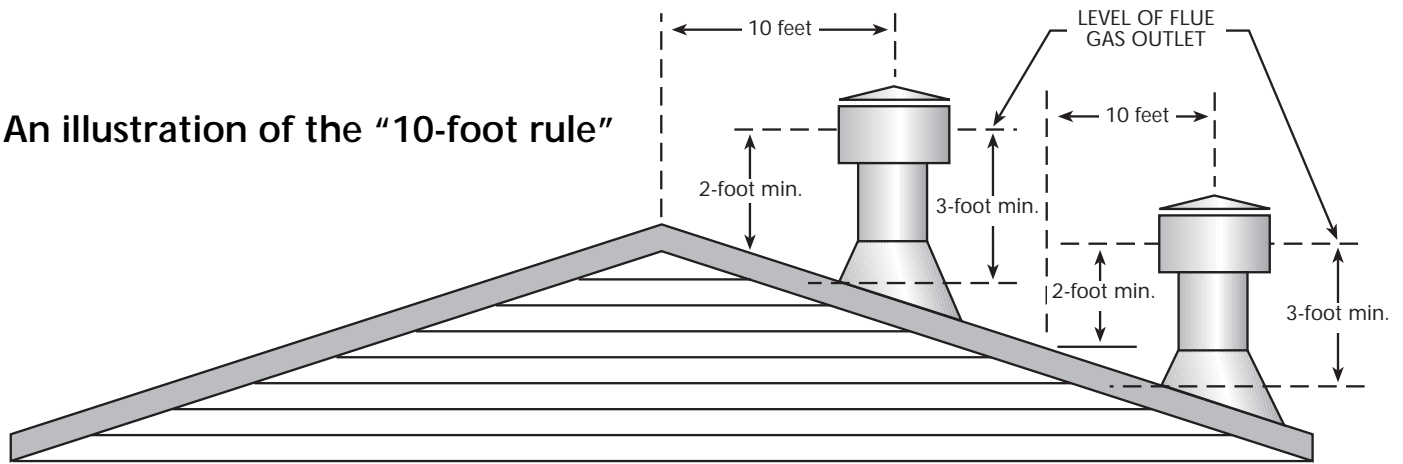

## Follow codes for correct fireplace chimney installation

By Mark Campion

When manufactured homes leave the factory, fireplace chimneys are shipped loose due to height restrictions on our roads. Once the home is set, chimneys are assembled by installers or service crews, who need to be aware of the “10-foot rule.”

The “10-foot rule” is not specifically referred to in the Oregon Manufactured Dwelling & Park Specialty Code. It is HUD 3280.709(g) (1) (vii), which states that the top of the chimney must be at least two feet above any portion of the home’s roof within 10 feet. In addition, the chimney must be at least three feet tall where it passes through the roof. See the diagram, which best illustrates the code language.

Notice that the three-foot minimum height is measured from the uphill side of the chimney to the top of

the flue pipe, not to the spark arrestor. If you measure from the downhill side of the chimney to the top of the spark arrestor, the chimney will not be tall enough.

If the chimney is not tall enough, the fireplace may not draft well, allowing smoke to back-draft into the home, which is dangerous.

All of the shipped-loose chimney parts must be installed. It is highly unlikely that the factory has shipped extra pipe sections that do not need to be used. In fact, depending on the slope of the roof and the chimney location (near the peak or near the eave), you may need to add an extra section of flue pipe. It’s a good reason to always measure the installation when you are done. ■

## Vinyl skirting, close-up trim require extra care

By Mark Campion

Vinyl skirting requires special attention during application that may not be clearly spelled out in manufacturers’ installation instructions.

Oregon Manufactured Dwelling & Park Specialty Code 3-9.1(i) (j) requires that skirting protect the crawlspace from moisture and prevent water from becoming trapped between the skirting and the home’s siding or trim. Even when vinyl skirting is used on an aboveground set (vs. pit set), and the home has cementitious siding, the code still applies.

The overlooked area of application with vinyl skirting is the top attachment rail. Rainwater can run down behind the rail into the crawlspace under the home.

The water can wick up the cut edge of the home’s siding. To prevent this, and to accomplish the objectives of the code, a bead of caulk should be run along the top horizontal edge of the attachment rail. This will take care of both issues.

Caulking is often overlooked on exterior close-up trim, too. The vertical trim board that overlaps sections of multi-wide homes at the endwall needs to be caulked on both side from top to bottom (OMDPSC 3-11.3 Weather Seal) to prevent rain from getting into the home.

Applying the caulking is a wise move for display models on dealer lots. ■

# Quizzin' Corner

By Irene Lickiss

It's time for another game. See if you can find the installer names hidden in this puzzle. They run right to left, left to right, bottom up, top down, horizontal, backward and forward.

Have fun!

P.S.: There is a hidden message! See if you can find it. Check your answer with the SAA group at BCD. ■

A	D	E	X	F	Y	H	L	M	O	P	Q	R	S	T	U	V	W	X	Y
N	M	L	O	T	T	S	U	P	N	H	E	O	L	K	X	M	W	R	Z
D	U	N	C	A	N	A	B	C	O	D	E	F	N	G	H	T	I	I	J
E	L	M	N	O	N	S	P	Q	S	R	S	T	I	U	V	W	N	X	K
R	Y	Z	B	O	O	Y	O	U	I	A	R	E	T	M	E	K	K	L	D
S	F	G	H	I	S	E	J	I	R	K	N	L	R	M	N	O	L	P	Q
O	R	S	D	U	L	L	T	N	R	U	V	A	A	W	X	Y	E	Z	J
N	K	L	M	N	I	N	O	O	A	P	K	A	M	M	M	E	R	Q	R
S	T	U	V	W	W	I	X	T	H	E	Y	Z	E	W	S	Y	U	G	A
R	E	X	P	R	E	K	S	I	R	S	U	T	I	L	E	I	T	Y	B
O	O	J	K	L	M	C	N	R	O	A	P	Q	U	S	R	N	M	I	T
D	H	O	L	C	O	M	B	F	B	P	M	R	S	T	M	Q	U	A	B
S	C	H	R	A	G	L	G	F	R	A	P	E	T	I	A	I	N	L	O
S	T	N	M	A	B	N	B	E	S	T	R	L	L	E	S	S	T	E	T
T	H	S	E	L	I	M	I	N	Q	C	A	G	U	E	T	S	N	H	R
M	I	O	N	L	R	E	L	S	I	E	H	Y	E	S	E	N	O	J	A
M	E	N	R	S	I	S	T	H	E	B	S	U	T	R	N	L	S	E	R
A	D	E	R	O	E	S	T	N	D	T	O	P	R	N	P	E	T	D	Q
M	T	A	P	R	T	G	H	L	O	P	E	R	S	W	I	L	A	M	E
S	P	Q	U	I	M	O	E	S	G	M	R	O	W	P	C	X	W	D	E

Anderson	Dull	Holcomb	Martin	Rios	Sterling
Barger	Duncan	Johnson	Masten	Roberson	Tramel
Cox	Friton	Jones	McKinley	Schrag	Watson
Cressey	Harrison	Kammer	Newman	Sharp	Wilson
Deroest	Heisler	Kloehn	Ott	Smith	Winkler

## Meet Ann McGovern, new insignia specialist

---

By Ann McGovern

I'm the new face at the insignia desk. I've taken over for Irene Lickiss, who is now in the Elevator Section.

I came to Building Codes in January as a college-work-experience student from Chemeketa Community College. I will graduate in June with a business technology certificate.



Ann McGovern

I'm enjoying my new position as insignia specialist, working with the RV and the installer programs in Statewide Services.

At home, I keep busy with my children and their many activities. I am a 4-H superintendent at the Marion County Fair for the pocket-pet and cat projects and a leader in a 4-H community club. I enjoy gardening, decorative painting, and sewing.

I look forward to meeting and working with all of you. My phone number is (503) 373-1257. ■

## New alternate construction requirements

---

By Dwight West

For those of you involved in the Fuqua Homes' alternate-construction process, there are some changes.

Fuqua now requires that sub-roof sheathing be removed between every other bay. The company is also requiring that a diagonal brace be installed on each end rafter. In the past, these were only required on 6:12 roofs. Also, make sure you know the length of the home; Fuqua has added an additional roof vent on homes that are more than 64 feet long.

For dealers, I suggest that when you schedule these homes to be set, you remind your contractors about these changes.

When you call Building Codes Division for an inspection, give us at least a week to respond. Call (503) 378-2620 for all alternate construction (AC) inspections. ■

## Tri-county readers, check out these newsletters

---

If your work takes you to Multnomah, Washington, or Clackamas counties, take a look at new code newsletters designed to help you.

The newsletters address code questions in the following areas:

- *News Flash*, electrical
- *News Splash*, plumbing
- *News Connect*, mechanical
- *News Site*, one- and two-family structural
- *News Line*, commercial builders

The newsletters contain the decisions from the tri-county code forums, which issue determinations for inspection standards for the three counties.

To sign up to have any or all of the newsletters mailed to you, contact the BCD Tri-County Services Center, 123 N.E. Third St., Portland, OR 97232, telephone (503) 872-6731.

You can also see current and past issues of the newsletters on the Web site, [www.oregonbcd.org](http://www.oregonbcd.org). Click on "Tri-County," then on "Code Forum" to find links to each of the code areas and related newsletters.

In addition, you can see current and past issues of Codelink and other Building Codes Division newsletters by clicking on "Publications." ■

# Good installations recognized

---

By Al Rust

On behalf of the manufactured housing industry in Oregon, Building Codes Division recognizes the following installers and their crews for having installed homes during the October-December 2002 quarter with no nonconformances:

- Philip A. Bond, Donald
- Gregory V. Theroux, Oregon City
- Steven L. McKinley, Siletz
- Matthew Chaney, Coos Bay
- Guy P. Hurlbert, Bend
- Troy J. Bayless, Oregon City
- Brian Shimer, Myrtle Creek

The names in this article were taken from inspection reports sent to this division from jurisdictions around the state. Many thanks to inspectors for participating in this program. ■

440-2667 (4/03/COM)

*Manufactured Home Update* is a regular publication of the Building Codes Division of the Oregon Department of Consumer & Business Services.

Editing, design, and production  
DCBS Communications



BCD Administrator  
Mark S. Long

All information in this newsletter is in the public domain and may be reprinted without permission.

In compliance with the Americans with Disabilities Act (ADA), this publication is available in alternative formats. Call DCBS Communications, (503) 947-7006.

If you want to be included on our *Manufactured Home Update* mailing list, please call Albert Endres, (503) 378-5975.



**Building Codes Division**  
1535 Edgewater NE, Salem, Oregon  
Mailing address:  
P.O. Box 14770, Salem OR 97309-0404

PRSRST STD  
US POSTAGE  
**PAID**  
SALEM OR  
PERMIT NO 24