

CHAPTER 3  
INSTALLATION REQUIREMENTS

SECTION 301  
GENERAL

301.1 Scope. The provisions of this chapter shall govern the installation of photovoltaic (PV) components including location, materials and structural support. Where the installation of PV systems is not covered by this chapter the installation shall be in compliance with the applicable provisions of the Oregon Building Code as defined in ORS 455.020.

Exception: Where applicable provisions are specified, compliance with the Oregon Residential Specialty Code (ORSC) shall satisfy the requirements of this section when the PV system is installed on;

1.1 Detached one and two family dwellings and townhouses classified as Group R-3, and Group U Occupancies; and

1.2 Residences used for family daycare or foster care in accordance with ORS Chapters 418, 443 and 657A; and

1.3 Detached Congregate residences (each accommodating 10 persons or less) and detached lodging houses containing not more than five guest rooms.

SECTION 302  
DEFINITIONS

302.1 General. The following words and terms shall, for the purposes of this chapter and as used elsewhere in this code, have the meanings shown herein.

**ACCESSIBLE ROOF.** A roof plane that has an eave not more than 20 feet (7620 mm) above grade with an adjacent a Firefighters Staging Area.

**CONVENTIONAL LIGHT-FRAME WOOD CONSTRUCTION.** A type of construction whose primary structural elements are formed by a system of repetitive wood-framing members in accordance with OSSC Section 2308 or the ORSC as applicable.

**CUTOUT.** An area adjacent to a pathway for use by firefighters to cut a vent if needed. Cutouts shall not be less than 30 inches (762 mm) in any dimension.

**FIREFIGHTERS STAGING AREA.** A level area on the ground that is not less than 3 feet wide and extends not less than 8 feet from the structure.

**NON-OCCUPIED ACCESSORY STRUCTURE.** A structure normally not occupied such as a garage, carport, shed, or agricultural building.

PATHWAY. Unobstructed route provided within or around the array to provide unimpeded access for firefighting purposes.

RACKING. A system of components that directly supports the PV modules and transfers the applied loads to the building structure or ground-supported structure

SELF BALLASTED SYSTEM A PV array and racking/supporting structure that is not permanently attached to the solar roof.

SOLAR ROOF. A roof ~~plane~~ on which a solar array is installed.

### SECTION 303 MINIMUM STANDARDS AND QUALITY

303.1 General. Photovoltaic (PV) components, racking, support structures and attachments shall be in accordance with the provisions of this chapter. PV systems shall be designed and installed in accordance with this code and the manufacturer's installation instructions.

303.2 Type of Construction. PV systems, including supporting structure, shall comply with the requirements of OSSC Chapter 6 for the structures required to be of non-combustible type of construction or the ORSC as applicable.

303.3 Material standards. PV modules shall be certified in accordance with UL1703 and shall be installed in accordance with the manufacturer's installation instructions.

303.4 Certification Requirements. PV racking, support structures and attachments shall comply with one of the following:

1. Certified to UL 1703 by a Nationally Recognized Testing Laboratory and installed in accordance with the manufacturers installation instructions.
2. Designed by an Oregon Licensed Engineer or Architect.
3. Field evaluation by an Approved Field Evaluation Firm.
4. Approval by the Authority Having Jurisdiction.

303.5 Fire classification. Rooftop mounted PV systems shall have a fire classification that is equal to or greater than the roof assembly required by OSSC Section 1505.1.

303.6 Weather protection. All components of the PV system exposed to the weather shall be constructed of materials approved for exterior locations and protected from corrosion or deterioration.

SECTION 304  
LOCATION

304.1 General. The location of Photovoltaic (PV) components, racking, support structures and attachments shall be in accordance with the provisions of this chapter.

304.2 Zoning requirements. The installation of PV systems shall comply with the requirements of the zoning requirements of the Authority Having Jurisdiction (AHJ).

304.3 Flood Hazard Areas. Installation of PV systems within flood hazard areas, as defined by the AHJ, shall comply with the OSSC or ORSC Section R324 as applicable.

304.4 Building Egress. PV systems shall not be installed in locations that would restrict, or otherwise prevent the use of, the required means of egress and emergency escape and rescue. The means of egress shall comply with Chapter 10 of the OSSC or ORSC Section R310 and R311 as applicable.

304.5 Light and Ventilation. PV systems shall not be installed in locations that would restrict the required light and ventilation. Light and ventilation shall comply with OSSC Chapter 12 or ORSC Section R303 as applicable.

304.6 Rooftop Vent and Drain Clearances. PV systems shall not be installed in locations that would restrict the function of plumbing or mechanical vents, skylights, drains or other rooftop features.

304.7 Mechanical Equipment Clearances. PV systems shall be installed with clearances to mechanical equipment consistent with the Oregon Mechanical Specialty Code.

304.8 Roof Drainage. PV systems shall not be installed in a manner that would obstruct roof drainage. Roof valleys shall be unobstructed for 12 inches (305 mm) each side of the lowpoint.

304.9 Fire Fighter Access and Escape. To provide access and escape for Fire Fighters the location of roof-mounted PV modules shall comply with the requirements of this section.

304.9.1 General Pathway Locations. All PV installations shall include a 36 inch wide (914 mm) pathway maintained along three sides of the solar roof. The bottom edge of a sloped roof shall not be used as a pathway. all roof edges and peaks ridges. All pathways shall be measured from the edge of the roof or ridge to the solar array or any portion thereof.

Exceptions:

1. Arrays installed on one and two family dwellings may comply with the following provisions based on roof design:

A. A-Where the solar roof is sloped and accessible and there is an adjacent accessible roof plane; a single pathway not less than 36 inches (914 mm) wide shall be provided from the eave to the ridge of an accessible solar roof. Not less than 12 inches (305 mm) of the pathway shall be structurally supported by being

located directly above the building cavity or by other suitable means. A single pathway not less than 12 inches (305 mm) wide shall be provided along the solar roof ridge line to allow ladder hooks from the adjacent accessible roof plane.

- B. Where the solar roof is sloped and not accessible and there is an adjacent accessible roof plane a single pathway not less than 12 inches (305 mm) wide shall be provided along the solar roof ridge line to allow ladder hooks.
- C. Where the solar roof is sloped and accessible and there is an adjacent non-accessible roof plane a single pathway not less than 36 inches (914 mm) wide shall be provided from the eave to the ridge of an accessible solar roof. Not less than 12 inches (305 mm) of the pathway shall be structurally supported by being located directly above the building cavity or by other suitable means. A single pathway not less than 36 inches (914 mm) wide shall be provided along the solar roof ridge line to allow ladder hooks from the adjacent accessible roof plane..
- D. Where the solar roof is sloped and not accessible and there is an adjacent non-accessible roof plane a single pathway not less than 36 inches (914 mm) wide shall be provided from the eave to the ridge of an accessible solar roof. Not less than 12 inches (305 mm) of the pathway shall be structurally supported by being located directly above the building cavity or by other suitable means. A single pathway not less than 12 inches (305 mm) wide shall be provided along the solar roof ridge line to allow ladder hooks from the adjacent accessible roof plane.

~~A single pathway not less than 36 inches (914 mm) wide shall be provided from the eave to the ridge of an accessible solar roof. Not less than 12 inches (305 mm) of the pathway shall be structurally supported by being located directly above the building cavity or by other suitable means. A single pathway not less than 12 inches (305 mm) wide shall be provided along the solar roof ridge line to allow ladder hooks from the adjacent accessible roof plane.~~

- ~~B. Where the solar roof is sloped and accessible with no adjacent roof plane:~~

~~A single pathway not less than 36 inches (914 mm) wide shall be provided from the eave to the ridge of an accessible solar roof. Not less than 12 inches (305 mm) of the pathway shall be structurally supported by being located directly above the building cavity or by other suitable means. A single pathway not less than 36 inches (914 mm) wide shall be provided along the solar roof ridge line with not less than 12 inches (305 mm) on either side.~~

- ~~E. C.~~ A solar roof that is flat shall have at least one pathway not less than 36 inches (914 mm) wide extending from an accessible edge to the opposite side of the roof with a second pathway running perpendicular to it that is not less than 36 inches (914 mm) wide and running the full length of the roof.

Place holder for "Figure"

2. Townhouses separated in accordance with ~~ORSCSRC R-xx 317.2 (contiguous roofs)~~ may be ~~treated as considered~~ one structure and comply with the provisions of ~~section 2a of 304.9.1 Exception 1 this section~~ where the units are under common ownership or an access easement ~~for a required pathway~~ is provided.

3. Pathways are not required on ~~non-habitable occupied~~ accessory structures provided they are separated from ~~occupied habitable~~ structures by a ~~610~~ feet (3048 mm) minimum separation distance or by a minimum two-hour fire ~~rated assembly wall~~.

304.9.2 Intermediate Pathway Locations. Systems that include a solar array section that is larger than 150 feet (-mm) measured in length or width shall have additional intermediate pathways. ~~An~~ intermediate pathways not less than 36" (914mm) wide separating the array shall be provided for every 150 feet (45720 mm) -of array measured in any one direction and including offset modules or angled installations. The maximum square footage of an array shall not exceed 22,500 ft<sup>2</sup>. (2090 m<sup>2</sup>) without the installation of an intermediate pathway. ~~Intermediate pathways shall comply with the general pathway requirements. (which are? 36 inch min., 12 inches at top if...should we list it here?)~~

304.9.3 Prohibited Locations. Pathways shall not be located in valleys.

304.9.4 ~~Vent~~ Cutouts. Each attic area, including attic areas separated by a fire rated assembly or draftstop, shall have not less than one cutout. All pathways shall have ~~vent cut-outs one or more cutouts~~ located adjacent to the pathway along the axis of the pathway. No point on the pathway shall be more than 25 feet (7620 mm) from a ~~vent~~ cut-out.

Exception:

1. Systems installed in accordance with 304.9.1 Exception 1 or 2.

~~1. Vent cut-outs shall not be less than 30 inches (762 mm) in any dimension.~~

304.9.6 Electrical Component Location.

304.9.6.1 Disconnects, j-boxes, combiner boxes or gutters shall not be located in any required pathway or cut-out.

304.9.6.2 Raceways on flat roofs that cross a required pathway shall be bridged to avoid tripping hazards. Raceways shall not be permitted in the required pathways on sloped roofs.

304.9.6.3 Raceways shall be visibly marked with the words "dc Conductors" in a manner suitable for the environment. The marking methods may include signage similar to signage used to designate water lines, natural gas lines, or other plumbing or mechanical lines.

304.9.6.4 Raceways containing dc conductors that are run through the roof and into the building shall be shall be located not less than 18 inches (457 mm) below the roof decking.

304.9.6.5 Combiner box disconnects shall be marked “Array disconnect 1 of X”. Letters shall be a minimum 1” in height, suitable for the environment and red in color.

A placard shall be posted at the ac service disconnecting means that accurately designates the location of all combiner box disconnects, inverters, dc raceways and the method of identification used for dc raceways. The placard shall be legible, durable and suitable for the environment.

**MOVE TO OESC:**

304.9.6.6 Every combiner box shall be installed with a visible dc disconnect. The disconnect shall be integral to or immediately adjacent to the combiner box. Disconnects shall be located adjacent to a pathway for accessibility.

The disconnect shall be marked “Array disconnect 1 of X”. Letters shall be a minimum 1” in height, suitable for the environment and red in color.

A placard shall be posted at the ac service disconnecting means that accurately designates the location of all combiner box disconnects, inverters, dc raceways and the method of identification used for dc raceways. The placard shall be legible, durable and suitable for the environment.

304.10 Alternate Installations. In accordance with section 104.11, an alternative material, design, location or method of construction may be approved by the building official.

SECTION 305  
STRUCTURAL

305.1 General. Photovoltaic (PV) components, racking, support structures and attachments shall be in accordance with the provisions of this section.

305.2 Module Attachment. PV modules shall be attached in accordance with the manufacturer’s installation instructions and to account for all loads, including dead loads, snow loads, wind loads and seismic loads, as prescribed by the OSSC.

305.3 Racking. Racking shall comply with this section.

305.3.1 Building Penetrations. All penetrations shall be flashed or sealed in a manner that prevents moisture from entering the wall and roof.

305.3.2 Structural Support and Attachment. Racking and racking supports shall be positively attached to the structural components through the use of screws, bolts, j-bolts, or other approved means in accordance with manufacturer’s specifications or be designed in accordance with the OSSC. Such attachment shall not be accomplished by the use of toenails or nails subject to withdrawal. Racking and racking supports shall be mounted to structural components and shall not be attached to wall or roof coverings, trim or structural sheathing as a means of structural support.

Exception:

1. Attachment to standing seam metal roofs w/ connectors per mfr installation instructions...need to expound w/ some criteria in accordance with the following ... per Jerry's language.
2. Certified non-penetrating or minimally penetrating systems shall be permitted when installed in accordance with the manufacturer's installation instructions.
- ~~3.~~ Sheathing or blocking per Jerry

305.3.3 Roof mounted racking. Roof-mounted supporting structures shall be certified in accordance with section 303.4, and shall be designed in accordance with accepted engineering practice, constructed and installed to safely support all loads, including dead loads, snow loads, wind loads and seismic loads as prescribed by the OSSC or in accordance with section 305.4.

305.3.4 Ground mounted racking. Ground-mounted supporting structures, and all parts thereof, shall be designed, constructed and installed to safely support all loads, including dead loads, flood loads, snow loads, wind loads and seismic loads as prescribed by the OSSC.

The bottom of modules shall be at least 18 inches (457 mm) clear from ground level.

305.4 Prescriptive Installations. Roof installations on conventional light-frame construction which complies with this section shall qualify as prescriptive and shall not require an engineered design if all of the following criteria are met:

1. Roof structure: The supporting roof framing shall be conventional light framed wood construction with pre-engineered trusses or roof framing members at a spacing of 24 (610 mm) inch on center maximum that comply with the applicable allowable span in Table 305.4.1 for the specific loads including snow loads not exceeding 50 psf and wind loads that do not exceed 100 MPH or 110 MPH in exposure B.

Exception: Roof framing in compliance with the applicable allowable span in Table 305.4.2 for the specific loads including snow loads not exceeding 70 psf and wind exposure is limited to exposure A, B or C shall satisfy the requirements of this section when the PV system is installed on;

1.1 Detached one and two family dwellings and townhouses classified as Group R-3, and Group U Occupancies; and

1.2 Residences used for family daycare or foster care in accordance with ORS Chapters 418, 443 and 657A; and

1.3 Detached Congregate residences (each accommodating 10 persons or less) and detached lodging houses containing not more than five guest rooms.

2. Roof materials. Roofing material shall be metal, single layer wood shingle or shake, or not more than two layers of composition shingle.
3. Loading: Modules shall either be directly attached to the roof framing or mounted to continuous rails that are attached directly to the roof framing. These attachments must be anchored to roof framing at a spacing no greater than 48 inches (1219 mm) on center maximum in any direction where snow loads do not exceed 25 psf and 24 inches on center maximum in any direction where snow loads exceed 25 psf. Installation shall comply with Figure 305.4(1) or 305.4(2). The combined weight of the PV modules and racking shall not exceed 4.5 pounds per square foot (xxx kPa).

Exception:

1. Attachment to standing seam metal roofs in accordance with the following ... per Jerry's language.
2. Certified non-penetrating or minimally penetrating systems shall be permitted when installed in accordance with the manufacturer's installation instructions.
3. Sheathing or blocking per Jerry

Place holder for "Table"

Place holder for "Figure 305."

4. Height: Maximum module height above roof shall be 18" from top of module to roof surface and in accordance with Figure 305.
5. Submittal Requirement. (Include a fill-in-the-blank form to be submitted stating rafter size/spacing/span, panel weight (psf), etc.

Place holder for "Figure"

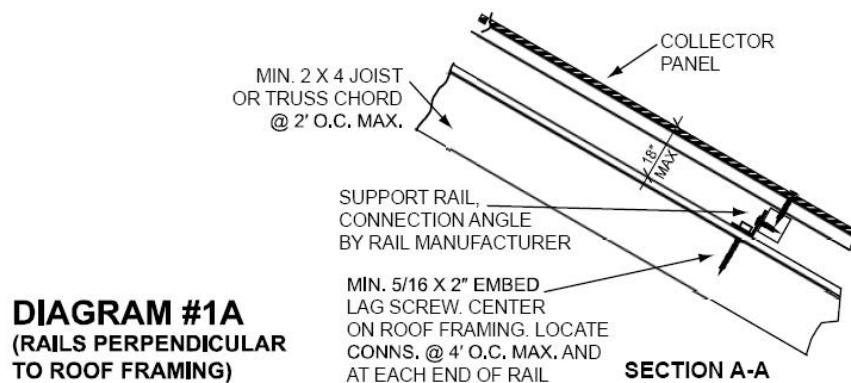

Figure 305.3.3.1.1(1) Installation – Rails perpendicular to framing members

Place holder for “Figure”

Figure 305.3.3.1.1(2) Installation – Rails parallel to framing members

UL 1703-02 Flat-Plate Photovoltaic Modules and Panels – with revisions through April 2008